

Dimensions in Inches  
Unless Otherwise Specified

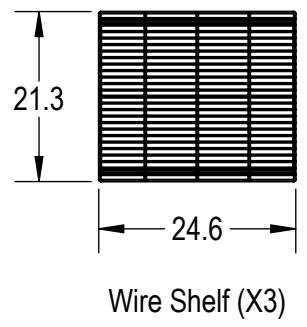

- Notes:
- Crated Weight: 526 lbs
  - Shelves adjustable in 1/2" increments. Minimum 2" spacing required
  - Weight Capacity: 90 lbs per shelf
  - Dimensions and components are subject to change without notice.
  - Some options may affect chamber performance.

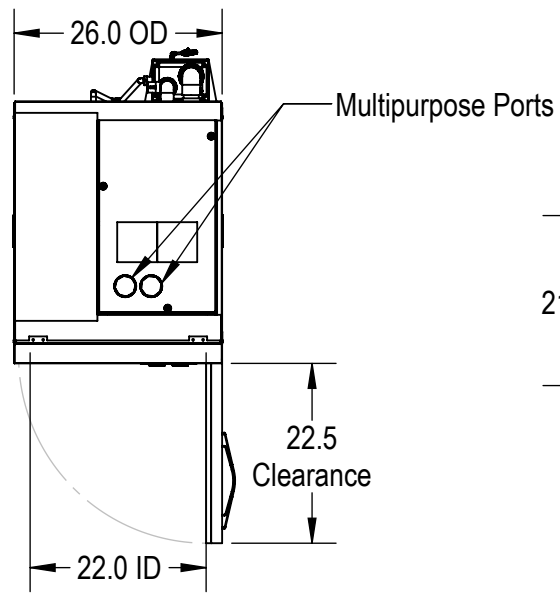
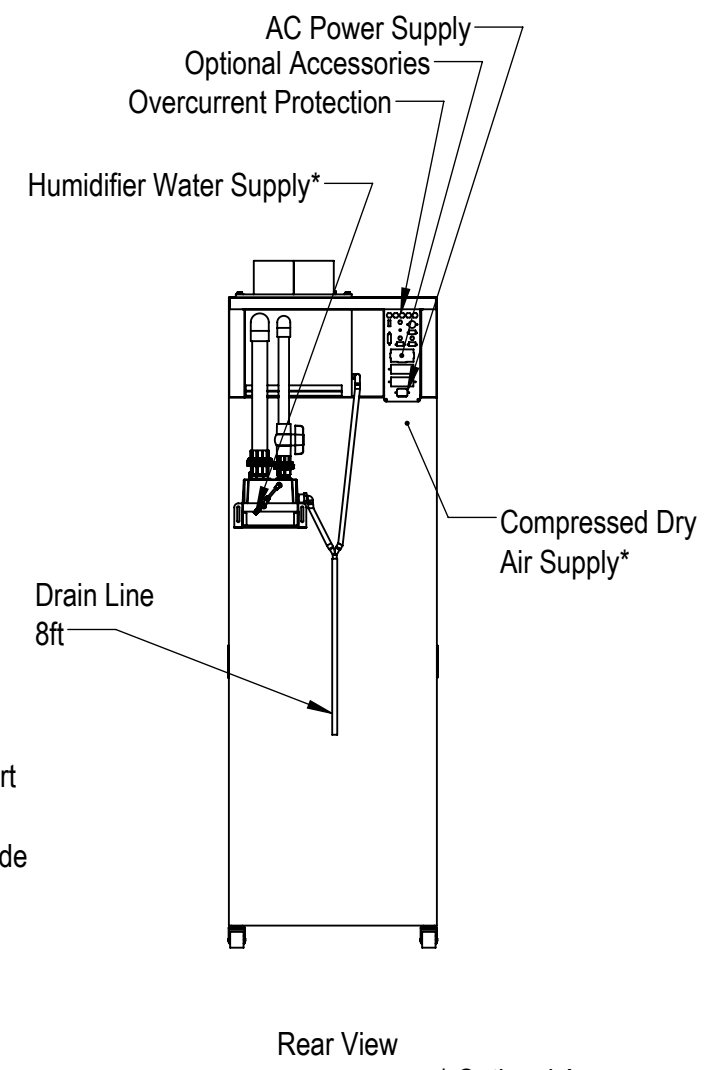
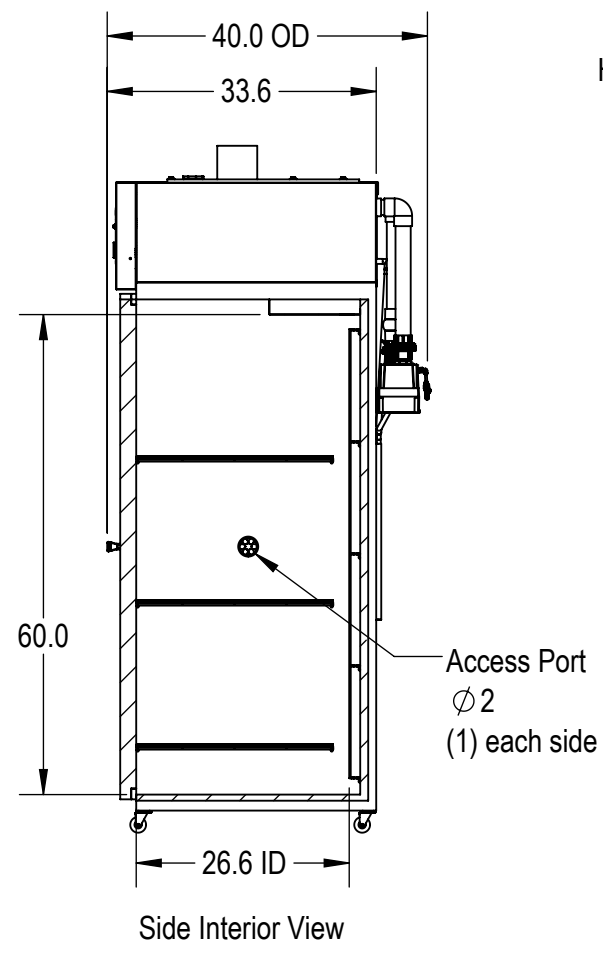
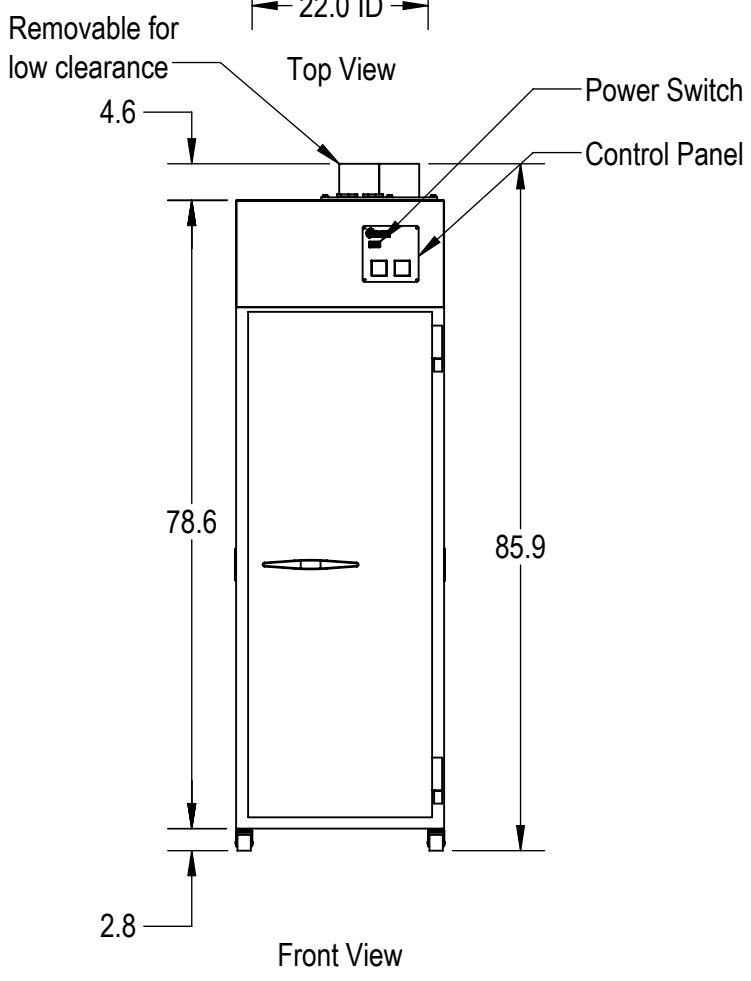

\* Optional Accessory